



R53VM -



R53VM -

R53VM DN32

R53VM DN32

R53VM

(AISI304)

R53VT DN32,
1" 1 1/4".

R53VT DN32

R53VM

18,

- 90
- 1 Mpa (10 bar)

ABS

- 1" 1 1/4"

- 50

18

- DN32
(),





R53VM-

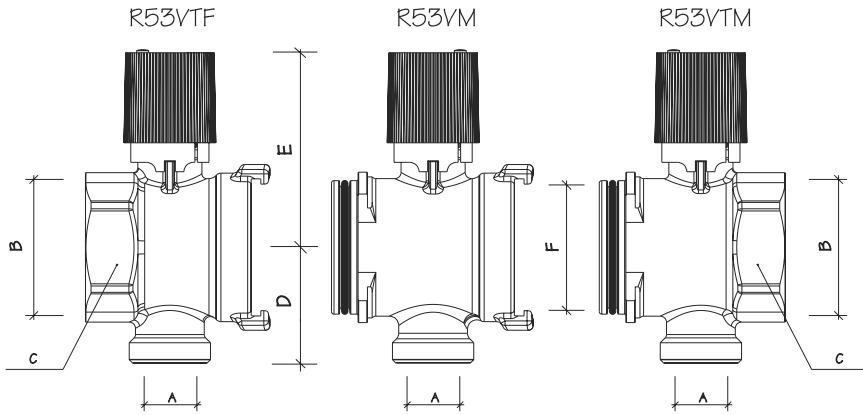

	A	B	C	D	E	F
R53VMY006	18	-	-	37	61	DN32
R53VTY006	18	1"	∅39	37	61	DN32
R53VTY007	18	1"1/4	∅48	37	61	DN32

R53VM



90

R53VT,
R53VM,

- 1 . R53VT
- 3 . R53VM;
- 5
- 2
- 1 . R53VT,





R53VM-

R53VT DN32,
1" 1"1/4



R501 R502,
(
R588D,

R500,



GIACOMINI

18,

R53VM

R53VT,
GIACOMINI

R476

R478,

R475

R479,

R477.

R522.

R53VM DN32,

KV 2,82

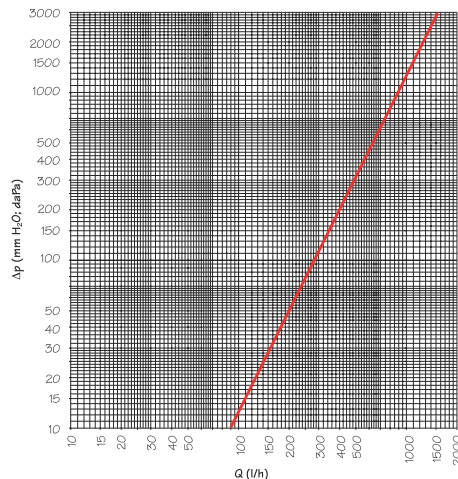



GIACOMINI SPA
Via per Alzo,39
28017 San Maurizio d'Opaglio (NO) ITALY
tel. 0322 923111 - fax 0322 96256
e-mail: info@giacomini.com
internet: www.giacomini.com

1618

· ” ”
· “ ” 253
./ : 02 / 85 69 174
· : +359 878 20 55 33
sales@terratherm-bg.com
www.terratherm-bg.com